



Productblad

VPL-15-RB1116 Motion Wood 16



Productomschrijving

Sporten in de buitenlucht, wie wil dit nou niet? Train je beenspieren, verbeter je conditie en blijf fit met dit calisthenics toestel.

Opties *



VPL-15-1116-1-GM-C18 en VPL-15-1116-1-RVS

Speelwaarden



Gebruikers



* Aan de opties kunnen extra kosten verbonden zijn.

Alle afbeeldingen en uitvoeringen onder voorbehoud.





VPL-15-RB1116 Motion Wood 16

Toestelspecificaties

Opvangzone	4,9 x 3,8 m
Obstakelvrije zone	4,9 x 3,8 m
Valhoogte	< 0,6 m
Afmetingen toestel	1,9 x 0,8 m
Totale hoogte	1,8 m

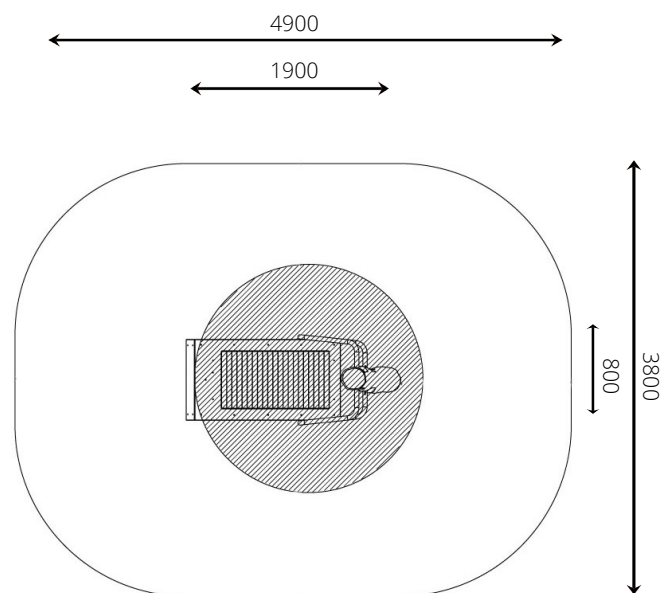

Materialen

Constructie | Robinia

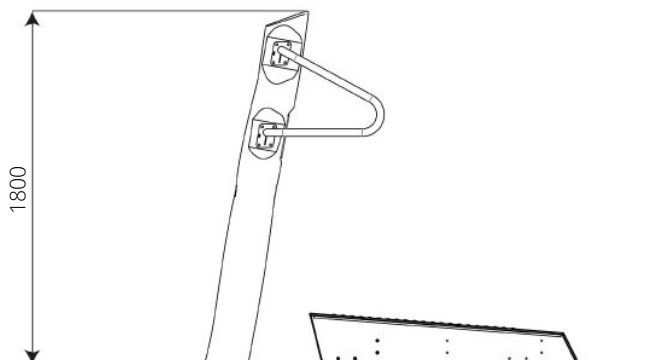

Ondergrondspecificaties

- ✓ Geen valdempende ondergrond vereist
- m² 16,5 m²

Materiaal	Omschrijving	Min. laagdikte	Max. valhoogte
Beton/steen			≤ 1000 mm
Gras			≤ 1500 mm
Boomschors Houtsnippen	20 - 80 mm	300 mm	≤ 2000 mm
	5 - 30 mm	400 mm	≤ 3000 mm
Zand Grind	0,2 - 2 mm *	300 mm	≤ 2000 mm
	2 - 8 mm *	400 mm	≤ 3000 mm
Overig	Naar beproeving volgens HIC (EN-1177)		Volgens beproeving
* korrelgrootte			

